

**NOTES:**

1. CONCRETE SHALL BE NORMAL CLASS N25 COMPLYING WITH THE REQUIREMENTS OF AS. 1379. REFER TO VICROADS STANDARD SPECIFICATION 703 FOR REQUIREMENTS OF CONCRETE TO BE USED IN EXTRUSION MACHINES.
2. REFER TO AUSTRROADS GUIDE TO ROAD DESIGN PART 3: GEOMETRIC DESIGN FOR THE RECOMMENDED USE OF KERBS AND CHANNELS.
3. WEAK PLANE JOINTS (WPJ) TO BE PLACED AT 2500 CENTRES.
4. CHAMFERS ARE 15mm X 15mm UNLESS OTHERWISE SHOWN.
5. ALL DIMENSIONS IN MILLIMETRES UNLESS OTHERWISE SHOWN.

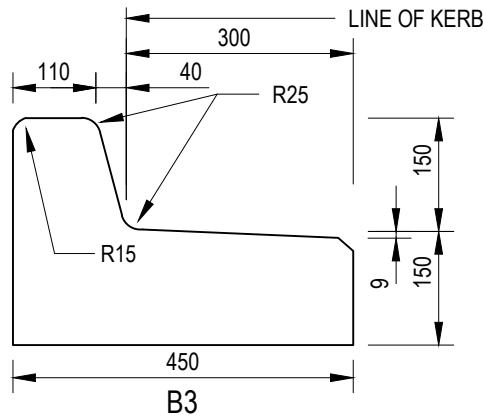

**450 WIDE BARRIER KERB**  
NOT TO SCALE

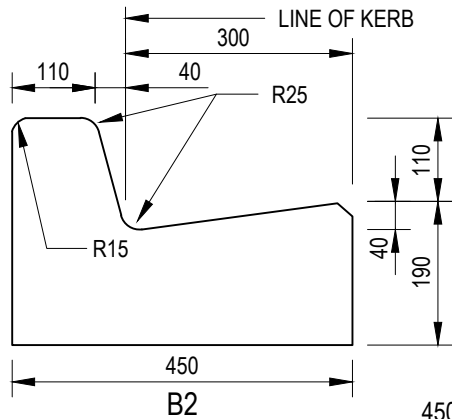
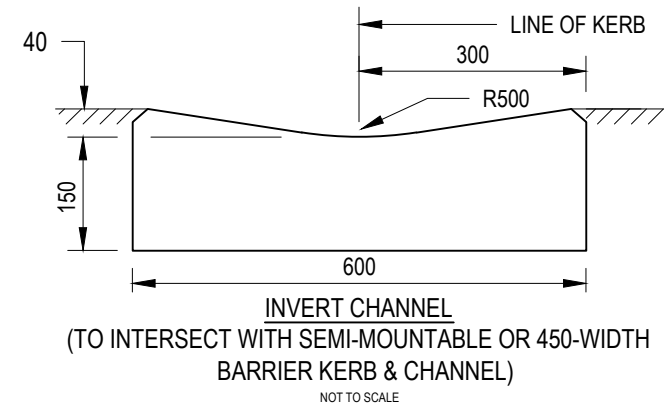
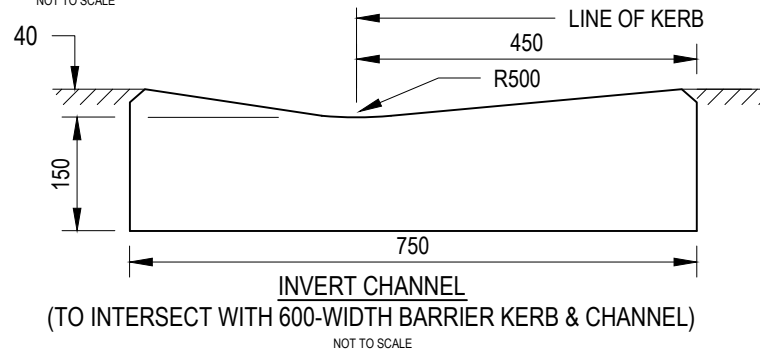
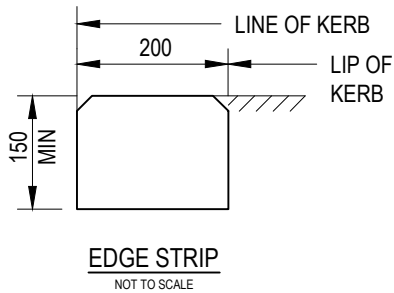

No	Revision	Note	Drawn	Checked	Approved	Date
0	FINAL ISSUE		DG	MM	-	16.11.15
No * indicates signatures on original issue of drawing or last revision of drawing						

